

GGF Datasheet for the Quality of Thermally Toughened Soda Lime Silicate Safety Glass for Building

4.4 August 2009

Contents

1. Scope Annex A
2. Definition, characteristics and manufacturing process.
3. Glass products
4. Fracture characteristics
5. Dimensions and tolerances
6. Edge and/or surface work, holes, notches and cut-outs
7. Shaped flat panes
8. Visual appearance
9. Properties
10. Glazing
11. Fragmentation test
12. Identification

Annex A. Tolerances and distortions specific to thermally toughened soda lime silicate safety glass produced by the vertical tong hung process

Annex B. Alternative Method of Measuring Roller Wave

Annex C. Examples of Particle Count

1. Scope

This datasheet defines the products and specifies the characteristics and associated measurement procedures and test methods for thermally toughened soda lime silicate safety glass that is in compliance with BS EN 12150.

Dimensional characteristics i.e. length, width, thickness and flatness, and their applicable tolerances are specified for thermally toughened soda lime silicate safety glass. Recommendations are also

made on the dimensions and tolerances of holes/cut-outs. Details of acceptable edgework are also given.

NOTE: Tolerances etc. specific to the vertical tong hung process are given in annex A.

A test method is described for assessing the fragmentation of thermally toughened soda lime silicate safety glass to show how the quality and consistency of manufacture can be controlled.

Other requirements, not specified in this datasheet, may apply to thermally toughened soda lime silicate safety glass which is incorporated into assemblies, e.g. laminated glass or insulating glass units, or undergo an additional treatment, e.g. coating. The additional requirements are specified in the appropriate product standard. Thermally toughened soda lime silicate safety glass, in this case, does not lose its mechanical or thermal characteristics.

This data sheet does not apply to curved thermally toughened soda lime silicate safety glass.

NOTE: GGF Data Sheet 5.20.3 covers these products.

2. Definitions, characteristics and manufacturing processes

Where appropriate these definitions have been taken from EN 12150-1.

2.1 edge deformation

Deformation of the edge caused by the tong marks.

2.2 edge lift (also referred to as edge dip)

Distortion produced in horizontal toughened glass, at the leading and trailing edge of the plate. This is a distortion produced by a reduction in surface flatness

2.3 enamelled thermally toughened soda lime silicate safety glass

Thermally toughened soda lime silicate safety glass which has a ceramic frit fired into the surface during the toughening process. After toughening the ceramic frit becomes an integral part of the glass

NOTE 1: Also known as opaque thermally toughened soda lime silicate safety glass.

NOTE 2: The application of the ceramic frit may be by a continuous process or discontinuous application, e.g. screen printing. The enamelled surface could be partially or wholly covered.

2.4 flat thermally toughened soda lime silicate safety glass

Thermally toughened soda lime silicate safety glass which has not been deliberately given a specific profile during manufacture

2.5 thermally toughened soda lime silicate safety glass

Glass within which a permanent surface compressive stress, additionally to the basic mechanical strength, has been induced by a controlled heating and cooling process in order to give it greatly increased resistance to mechanical and thermal stress and prescribed fragmentation characteristics

NOTE: The mechanical properties, i.e. thermal durability and mechanical strength, and safety properties, i.e. fragmentation characteristics, are generated by the level of surface compression. These properties are not size dependent.

2.6 horizontal process

Process in which the glass is supported on horizontal rollers

2.7 local distortion

Local deformation of vertically toughened glass underneath the tong marks



2.8 overall bow

deformation of the whole pane of horizontally and vertically toughened glass caused by the heating and cooling process

2.9 roller wave distortion

distortion produced in horizontal toughened glass as a result of the glass being in contact with the rollers during the toughening process. This is the surface distortion produced by a reduction in surface flatness

2.10 vertical tong hung process

process in which the glass is suspended by tongs

NOTE: This process is now of very minor importance.

3 Glass products

Thermally toughened soda lime silicate safety glass is made from a monolithic glass generally corresponding to one of the following standards:

- soda lime silicate glass products according to EN 572-1 including;
- float glass according to EN 572-2;
- drawn sheet glass according to EN 572-4;
- patterned glass according to EN 572-5;
- supplied and final cut sizes according to EN 572-8;
- a coated glass, with a substrate as above, that is in accordance with EN 1096-1.

Glass of nominal thicknesses other than those covered in the above standards is possible.

4 Fracture characteristics

The fracture characteristics of thermally toughened soda lime silicate safety glass are directly related to the amount of surface compression, these properties are not size dependent.

When the thermally toughened soda lime silicate safety glass is manufactured with an appropriate degree of surface compression then in the event of breakage the thermally toughened soda lime silicate safety glass fractures into numerous small pieces, the edges of which are generally relatively harmless.

NOTE: The degree of surface compression required is dependent upon glass type and thickness.

The fragmentation test described in clause 11 is undertaken on unrestrained test specimens.

The fragmentation in service may not always correspond to that determined during the fragmentation test due to the imposition of other stresses, i.e. from fixing or from reprocessing (e.g. laminating).

5 Dimensions and tolerances

5.1 Nominal thickness and thickness tolerances

The nominal thicknesses and thickness tolerances are those given in the relevant product standard (see clause 4), some of which are reproduced in Table 1a and b.

Table 1a — Nominal thicknesses and thickness tolerances – float and patterned glass. Dimensions in millimeters

Nominal Thickness d	Thickness tolerance for glass types	
	Float	Patterned
3	±0,2	±0,5
4	±0,2	±0,5
5	±0,2	±0,5
6	±0,2	±0,5
8	±0,3	±0,8
10	±0,3	±1,0
12	±0,3	±1,5
14	NM	±1,5
15	±0,5	±1,5
19	±1,0	±2,0
25	±1,0	NM

NM = not manufactured

Table 1b — Nominal thicknesses and thickness tolerances for drawn sheet and new antiques sheet glass. Dimensions in millimeters

The limits of squareness are described by deviation between diagonals. Limits are given in Table 3

Nominal Thickness d	Thickness tolerance for glass types	
	Drawn Sheet	New Antique Sheet Glass
3	±0,2	NM
4	±0,2	±0,3
5	±0,3	NM
6	±0,3	±0,3
8	±0,5	NM
10	±0,6	NM

NM = not manufactured

The thickness of a pane shall be determined as for the basic product. The measurement shall be taken at the centers of the 4 sides, and away from the area of any tong marks (see Figure 3), which may be present.

5.2 Width and length (sizes)

5.2.1 General

When thermally toughened soda lime silicate safety glass dimensions are quoted for rectangular panes, the first dimension shall be the width, B, and the second dimension the length, H, as shown in Figure 1. It shall be made clear which dimension is the width, B, and which is the length, H, when related to its installed position.

Figure 1 — Examples of width, B, and length, H, relative to the pane shape

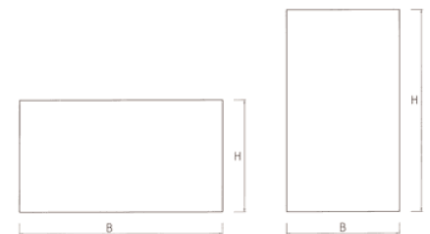

5.2.2 Maximum and minimum sizes

For maximum and minimum sizes, the manufacturer should be consulted.

5.2.3 Tolerances and squareness

The nominal dimensions for width and length being given, the finished pane shall not be larger than a prescribed rectangle resulting from the nominal dimensions increased by the tolerance, t, or smaller than a prescribed rectangle reduced by the tolerance, t. The sides of the prescribed rectangles are parallel to one another and these rectangles shall have a common centre. Limits are given in Table 2.

Figure 2 — Tolerance limits for dimensions of rectangular panes

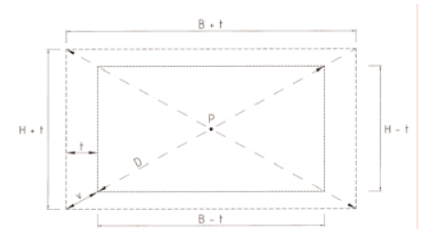

Key:

- B** – width
- H** – length
- T** – tolerance limits for dimensions
- D** – diagonals
- V** – deviation between diagonals
- P** – common centre of rectangles

Table 2 — Tolerances on width, B, and length, H

Dimensions in millimeters

Nominal dimension of side B or H	Tolerance t	
	Nominal glass thickness $d \leq 8$	Nominal glass thickness $d > 8$
≥ 2000	$\pm 2,0$	$\pm 3,0$
$2000 < B, H \leq 3000$	$\pm 3,0$	$\pm 4,0$
> 3000	$\pm 4,0$	$\pm 5,0$

Table 3 — Limit deviations for the difference between diagonals

Dimensions in millimeters

Limit deviation v on the difference between diagonals		
Nominal dimension of side B or H	Nominal glass thickness $d \leq 8$	Nominal glass thickness $d > 8$
≥ 2000	4	6
$2000 < B, H \leq 3000$	6	8
> 3000	8	10

5.2.4 Edge deformation produced by the vertical process

See Annex A.

5.3 Flatness

5.3.1 General

By the very nature of the toughening process, it is not possible to obtain a product as flat as annealed glass. This difference in flatness depends on the type of glass, e.g. coated etc., glass dimensions, i.e. the nominal thickness, the dimensions and the ratio between the dimensions, and the toughening process employed, i.e. vertical or horizontal.

There are four kinds of distortion:

- overall bow (see Figure 4);
- roller wave distortion (for horizontal toughened glass only) (see Figure 5);
- edge lift (for horizontal toughened glass only) (see Figure 6);

NOTE: Overall bow, roller wave and edge lift can, in general, be accommodated by the framing system.

- local distortion (for toughened glass produced by the vertical tong hung process only) (see Figure A1).

NOTE: Local distortion needs to be allowed for within the glazing materials and the weather seals. For special

requirements the manufacturers should be consulted.

Figure 3 — Representation of overall bow



Figure 4 — Representation of roller wave distortion

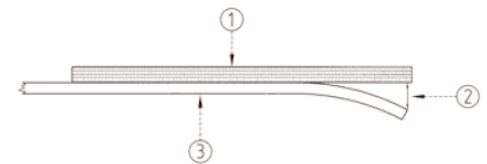

Key:

- 1 - straight edge
- 2 - edge lift
- 3 - thermally toughened glass

Figure 5 — Representation of edge lift

5.3.2 Measurement of overall bow

The pane of glass shall be placed in a vertical position and supported on its longer side by two load bearing blocks at the quarter points (see Figure 6).

The deformation shall be measured along the edges of the glass and along the diagonals, as the maximum distance between a straight metal ruler, or a stretched wire, and the concave surface of the glass (see Figure 4).

The value for the bow is then expressed as the deformation, in millimeters, divided by the measured length of the edge of the glass, or diagonal, in meters, as appropriate.

The measurement shall be carried out at room temperature.



Key:

- 1 - deformation for calculating overall bow
- 2 - B, or H, or diagonal length

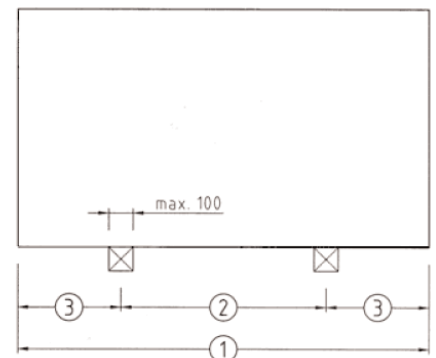

Key:

- 1 - B or H
- 2 - (B or H)/2
- 3 - (B or H)/4

Figure 6 — Support conditions for the measurement of overall bow

5.3.3 Measurement of roller wave

5.3.3.1 General

The roller wave is measured by means of a straight edge, or equivalent, being placed at right angles to the roller wave and bridging from peak to peak of the wave (see Figure 7).

NOTE: This section deals with measurement using a straight edge and feeler gauges. An alternative method is described in Annex B.

5.3.3.2 Apparatus

A straight edge: - length of between 300 mm and 400 mm.

NOTE: The actual length of straight edge required will depend upon the wavelength of the roller wave.

Feeler gauges: - various thicknesses in units of 0,05 mm.

5.3.3.3 Method

Place the straight edge so that it bridges across adjacent peaks. Insert the feeler gauge between the glass surface and the straight edge. Increase the thickness of the feeler gauges until they just fill the gap between glass surface and the straight edge. Record the thickness of feeler gauge(s) to an accuracy of 0,05 mm.

Repeat the measurement at several places over the glass surface.

The measured roller wave distortion is the maximum value measured. The maximum values are given in Table 4.

5.3.3.4 Limitations

The following limitations apply:

- The roller wave can only be measured on panes with a dimension greater than 600 mm measured at right angles to the roller waves.
- The roller wave cannot be measured in an exclusion area that is 150 mm from the edges of the pane. The apparatus should not be used in the exclusion area.
- Panes with an overall bow shall be laid on a flat support. This will allow gravity to flatten out the overall bow and hence give a truer result for the roller wave.

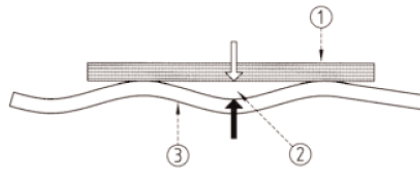

Key:
 1 - straight edge
 2 - roller wave distortion
 2 - thermally toughened glass

Figure 7 — Measurement of roller wave distortion

5.3.4 Measurement of edge lift (for horizontal toughened only)

The glass shall be placed on a flat support with the edge lift overhanging the edge of the support by between 50 mm and 100 mm. The straight edge is placed on the peaks of the roller waves and the gap between the ruler and the glass measured using a feeler gauge (see Figure 8).

The maximum values for edge lift are given in Table 5.

The values in Table 5 only apply to thermally toughened glass having edgework complying with Figures 9 to Figure 12. For profiled edges or other types of edgework contact the manufacturer.

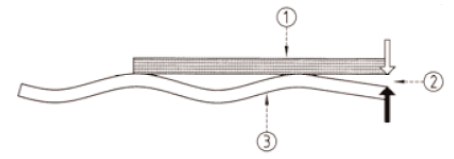

Key:
 1 - straight edge
 2 - edge lift
 2 - thermally toughened glass

Figure 8 — Measurement of edge lift

5.3.5 Measurement of local distortion (for vertical toughened glass only)

See Annex A.1.2

5.3.6 Limitation on overall bow, roller waves and edge lift for horizontal toughened glass

The maximum allowable values for the overall bow, when measured according to 5.3.2, for roller waves, when measured according to 5.3.3 and edge lift, when measured according to 5.3.4 are given in Tables 4 and 5. The values only apply to thermally toughened soda lime silicate safety glass without holes and/or notches and/or cut-outs.

Glass Type	Maximum value for distortion	
	Overall bow mm/m	Roller wave mm
Uncoated float glass in accordance with EN 572-1 and EN 572-2	3,0	0,3
Others (a)	4,0	0,5
(a) For enamelled glass that is not covered over the whole surface the manufacturer should be consulted.		
Note: Dependant upon the wave length of the roller wave an appropriate length of gauge has to be used		

Table 4 — Maximum values of overall bow and roller wave distortion for horizontal toughened glass

Dimensions in millimeters

Glass Types	Thickness of glass	Maximum Value
Uncoated float glass in accordance with EN 572-1 and EN 572-2	3,0	0,5
	4 to 5	0,4
	6 to 25	0,3
Others (a)	all	0,5

(a) For enamelled glass that is not covered over the whole surface the manufacturer should be consulted.

Note: Dependant upon the wave length of the roller wave an appropriate length of gauge has to be used

Table 5 — Maximum values for edge lift for horizontal toughened glass

5.3.7 Limitation on overall bow and local distortion for vertical toughened glass

See Annex A.1.3.

5.3.8 Other distortions

The incorporation of holes and/or notches in a plate gives the possibility of distortions being produced during the toughening process as a result of the absence of glass and/or an increase in unsupported edges. The magnitude of these distortions will generally be less than edge lift in horizontally toughened glass or the local distortion in vertically toughened glass.

6 Edge and/or surface work, holes, notches and cut-outs

6.1 Warning

Thermally toughened soda lime silicate safety glass should not be cut, sawed, drilled, edge worked or surface finished (e.g. sandblasting, acid etching) after toughening because the risk of breakage is increased or the glass can be destroyed immediately.

6.2 Edge working of glass to be thermally toughened.

The simplest type of edge working is the arrisred edge (see Figure 9). Common types of edge working are shown in Figures 9 to Figure 12.

For specialist edge work, such as 'water jet cutting', the manufacturers should be consulted.

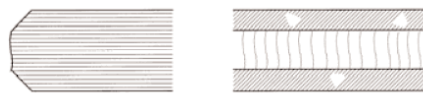

Figure 9 — Arrisred edge (with blank spots)



Figure 10 — Ground edge (with blank spots)



Figure 11 — Smooth ground edge (no blank spots)



Figure 12 — Polished edge

6.3 Profiled edges

Various other edge profiles can be manufactured with different types of edgework. This kind of product is not covered by Table 5. Corners need not to be treated unless required by the customer.

6.4 Round holes

6.4.1 General

This standard considers only round holes in glass that is not less than 4 mm nominal thickness. The manufacturers should be consulted about edge working of holes.

This edge work applies only to the perimeter

6.4.2 Diameter of holes

The diameter of holes, \varnothing , shall not, in general, be less than the nominal thickness of the glass. For smaller holes, the manufacturers should be consulted.

6.4.3 Limitations on position of holes

In general, the limitations on the positions of holes either relative to the edges of the glass pane, the corners of the glass pane or to each other depends on:

- the nominal glass thickness (d);
- the dimensions of the pane (B, H);
- the hole diameter (\varnothing);
- the shape of the pane;
- the number of holes.

The recommendations given below are those which are normally available and are limited to panes with a maximum of 4 holes.

1) The distance, a, of the edge of a hole to the glass edge should be not less than 2d.

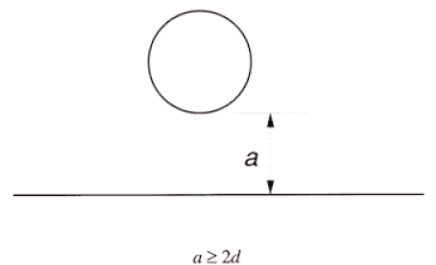

Figure 13 — Relationship between hole and edge of pane

2) The distance, b, between the edges of two holes should be not less than 2d.

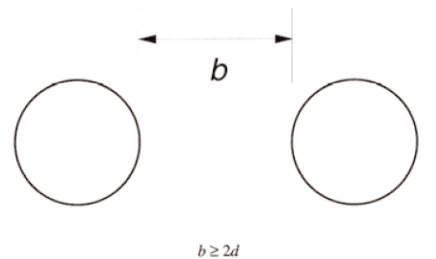

Figure 14 — Relationship between two holes

3) The distance, c, of the edge of a hole to the corner of the glass should be not less than 6d.

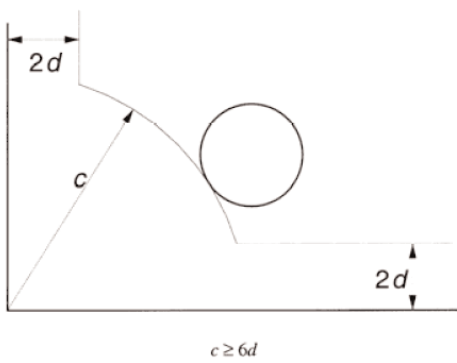

Figure 15 — Relationship between hole and corner of pane

NOTE If one of the distances from the edge of the hole to the edge of the glass is less than 35 mm, it can be necessary to position the hole asymmetrically with respect to the corner. The manufacturers should be consulted.

6.4.4 Tolerances on hole diameters

The tolerances on diameters of holes are given in Table 7.

Nominal hole diameter \varnothing	Tolerance
$4 < \varnothing = 20$	$\pm 1,0$
$20 < \varnothing = 100$	$\pm 2,0$
$100 < \varnothing$	consult the manufacturer

Table 7 – Tolerances on hole diameters

6.4.5 Tolerances on position of holes

The tolerances on positions of holes are the same as the tolerances on the width, B, and the length, H (see Table 2). The positions of holes are measured in two directions at right angles (x- and y- axes) from a datum point to the centre of the holes. The datum point is generally chosen as a real or virtual corner of the pane (see Figure 16 for examples).

The position of a hole (X,Y) is $(x \pm t, y \pm t)$,

where x and y are the required dimensions and t is the tolerance from Table 2.

NOTE: Manufacturers should be consulted if tighter tolerances on hole positions are required.

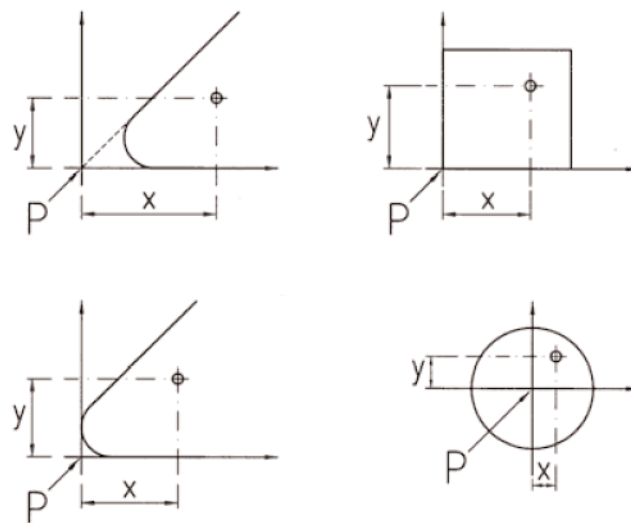

P – datum point

Figure 16 — Examples of the positioning of holes relative to the datum point

6.5 Holes/others

There are available countersunk holes, see Figure 17. The manufacturer shall be consulted for the tolerances on hole position, hole shape/dimensions and edge work.



Figure 17 — Countersunk hole

6.6 Notches and cut-outs

Many configurations of notches and cut-outs can be manufactured, for examples see Figures 18a and 18b.

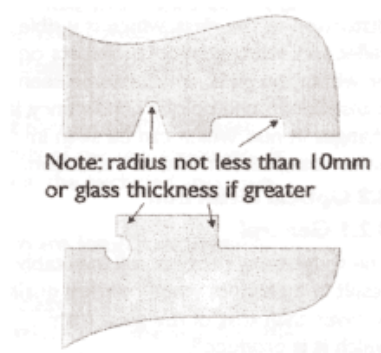

Figure 18a — Examples of notches

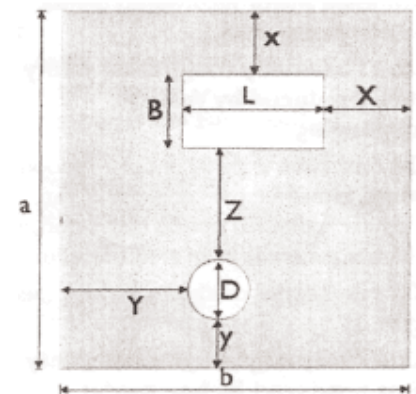

Figure 18b — Examples of cut-outs

Limitations on cut outs as shown in figure 18b:

- B, L and D < a/3 or b/3 whichever is the smaller;
- X and x not less than the smaller of L/2 or B/2;
- Y and y not less than D;
- Z not less than the larger of B/2, or L/2 and D/2

The manufacturer should be consulted about edge working of notches and cut-outs.

7 Shaped panes

Many non-rectangular shapes can be manufactured and manufacturers should be consulted.

8. Visual appearance

8.1 General

This section covers optical quality i.e. distortion of the glass which is visible in reflection; visual quality, i.e. defects on or

within the glass, which can be seen in transmission; and colour consistency, i.e. changes in hue, which can be seen in either transmission and/or reflection.

8.2. Optical distortion

8.2.1 General

The toughening process will inevitably result in a product whose optical quality is lower than that of the glass from which it is produced.

Surface distortion is produced by a reduction in the surface flatness, which can be seen particularly in reflection. This can be exacerbated when the glass used is body tinted, surface coated (including post-toughening coating) or enamelled and/or incorporated into insulating glass units.

8.2.2 Thermally toughened soda lime silicate safety glass produced by vertical toughening

(see Annex 2.1)

8.2.3 Thermally toughened soda lime silicate safety glass produced by horizontal toughening

While the hot glass is in contact with the rollers during the toughening process, a surface distortion is produced by a reduction in surface flatness, known as roller wave. Roller wave is generally noticed in reflection.

Thermally toughened glass, may show signs of small imprints in the surface (roller pick-up/pluck). This is a result of the length of time the glass spends in the furnace. Therefore the thicker the glass the more pronounced this could be.

NOTE: Toughenable low-e glass requires longer in the furnace.

8.2.4. Roller wave

On toughened sheet glass, or toughened patterned glass, it is not possible to measure roller wave, due to the inherent distortion of the basic glass.

Method of measuring roller wave distortion is given in clause 5.3.3 and limits for acceptance in Table 4. An alternative measurement method is given in Annex B

8.3 Anisotropy (iridescence)

The thermal toughening process produces areas of different stress in the cross section of the glass. These areas of stress produce a bi-refracting effect in the glass, which is visible in polarised light.

The viewing of thermally toughened soda lime silicate safety glass under polarized light results in areas of stress showing up as

coloured zones. These zones are, known as "leopard spots". Polarised light occurs in normal daylight. The amount of polarized light depends on the weather and the angle of the sun. The bi-refracting effect is more noticeable either at a glancing angle or through polarized spectacles.

8.4 Visual quality

8.4.1. Body faults, e.g. seeds, bubbles

The number, size and distribution of seeds, bubbles, etc. are defined for the glasses under consideration in the appropriate parts of EN 572.

No change will occur as a result of the toughening process.

Assessment of body faults should be undertaken using the method/criteria given, for the basic glasses in the appropriate parts of EN 572.

8.4.2 Surface faults e.g. scars, scratches

Toughened safety glass shall be deemed acceptable if the following phenomena are neither obtrusive nor bunched: hairlines or blobs; fine scratches not more than 25mm long; minute imbedded particles. Obtrusiveness of blemishes shall be judged by looking through the glass, not at it, when standing at right angles to it on the room side at a distance of not less than 3 metres in natural daylight and not in direct sunlight. The area to be viewed is the normal vision area with the exception of a 50mm wide band around the perimeter of the glass.

Pattern ghosting can occur on glasses with a textured finish.

8.5 Colour consistency

8.5.1 Clear glass

Clear glass from different manufacturers may show differences in hue.

8.5.2 Body tinted glass

Toughening will not produce any significant variation in colour. However, if a piece of toughened body tinted glass is placed next to a piece of annealed body tinted glass there may be a discernible difference.

A far larger problem will occur if different thicknesses of body-tinted glass are placed side by side as the colour is throughout the glass thickness. This can occur in those areas where toughened safety glass is required and an attempt is made to use the increased strength of the toughened safety glass by reducing the thickness of the glass. Body tinted glass from different manufacturers, or from different batches

from the same source manufacturer can show different shades.

8.5.3 Surface coated glass

As a general rule those surface coated glasses which can be toughened may exhibit different visual characteristics or a slight colour variation as a result of toughening. Care should be taken to ensure that the coated surface is not contaminated before toughening by, for example oil, grease, sweat, etc, as these materials may be burnt in during the toughening process. This could produce patches on the coating where there is a significant colour variation.

Glass, which is coated after toughening, will be within the same manufacturers colour tolerance as coated annealed glass.

8.5.4 Enamelled toughened safety glass

With this product the 'colour' results from the firing in of a ceramic frit. No colour variation will result from the toughening process itself.

However, the manufacturer should be consulted as to the likely tolerances on the colour and the possible variation between batches of ceramic frit. There is also a possibility that a colour variation may be noticeable if panes of different glass thickness or from different basic glass supplies are placed side by side.

9 Properties

9.1 Thermal durability

The mechanical properties of thermally toughened soda lime silicate safety glass are unchanged for continuous service up to 250°C and are unaffected by sub-zero temperatures. Thermally toughened soda lime silicate safety glass is capable of resisting both sudden temperature changes and temperature differentials up to 200 K.

NOTE: This property does not have any relationship to the fire resistance performance.

9.2 Mechanical strength

The value of mechanical strength can only be given as a statistical value associated with a particular probability of breakage and with a particular type of loading, i.e. four point bending test according to EN 1288 - 3.

The mechanical strength values apply to quasi-static loading over a short time, e.g. wind loading, and relate to a 5 % probability of breakage at the lower limit of the 95 % confidence interval. The values for different types of glass are listed in Table 8.

Type of glass	Minimum values for mechanical strength N/mm ²
Float – clear, tinted, coated	120
Enamelled Float*	75
Others	90

*Based on the enameled surface in tension

Table 8 — Minimum values for the mechanical strength of thermally toughened soda lime silicate safety glass

9.3 Classification of performance under accidental human impact

Thermally toughened soda lime silicate safety glass can be classified, as to its performance under accidental human impact, by testing in accordance with EN 12600.

The classification determined will be as follows:

I(C)₀

Where the value of ₀ is dependent upon the glass having a no-break performance at one of the three drop heights, i.e. 190mm, 450mm and 1200mm.

This means the classification could progress from:

I(C)₀; where a test specimen broke at 190mm,

to I(C)₃; where no test specimens broke at 190mm but a test specimen broke at 450mm,

to I(C)₂; where no test specimens broke at 190mm and 450mm but a test specimen broke at 1200mm, to I(C)₁; where no test specimens broke

10 Glazing and fixing

10.1 General

Glazing should be in accordance with BS6262, BS 8000 Part 7, Glass and Glazing Federation Glazing Manual or other appropriate standard.

Appropriate edge clearances must always be allowed taking into account glass type, e.g. clear or solar control and either single or double-glazed. Suitable insulation or cushioning should be used to prevent contact with hard materials.

10.2 Use of mechanical fixings

Glass to metal contact must be eliminated at all times by the use of gaskets, bushes, linings and setting blocks. These should be of appropriate material, which has been

lime silicate safety glass manufacturer. All fittings to which the glass is to be clamped must be free from high spots and/or burrs. Care should be taken to ensure that when the glass is being clamped the clamping pressure is evenly distributed. For more information see BS 6262-6: 2005.

11 Fragmentation test

11.1 General

The fragmentation test determines whether the glass breaks in the manner prescribed for a thermally toughened soda lime silicate safety glass.

11.2 Dimensions and number of test specimens

The dimensions of the test specimens shall be 360 mm x 1100 mm, without holes, notches or cut-outs.

11.3 Test procedure

Each test specimen shall be impacted, using a pointed steel tool, at a position 13 mm in from the longest edge of the test specimen at the mid-point of that edge, until breakage occurs (see Figure 19).

NOTE: The fragmentation characteristics of thermally toughened soda lime silicate safety glass are unaffected by temperatures between – 50°C and + 100°C.

Examples of steel tools are a hammer of about 75 g mass, a spring loaded centre punch, or other similar appliance with a hardened point. The radius of curvature of the point should be approximately 0,2 mm.

The test specimen shall be laid flat on a table without any mechanical constraint. In order to prevent scattering of the fragments, the specimen shall be simply held at the edges, e.g. by a small frame, adhesive tape etc., so that the fragments remain interlocked after breakage yet extension of the specimen is not hindered.

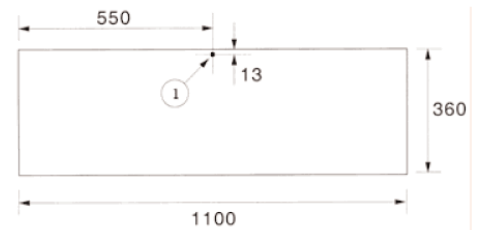

Key:

1 - impact point

Figure 19 — Position of impact point

For thermally toughened soda lime silicate safety glass manufactured by vertical tong hung process, the impact point shall not be on the tong mark edge.

11.4 Assessment of fragmentation

The particle count and measuring of the dimensions of the largest particle shall be made between 4 minutes to 5 minutes after fracture. An area of radius 100 mm, centered on the impact point, and a border of 25 mm, round the edge of the test specimen (see Figure 20), shall be excluded from the assessment.

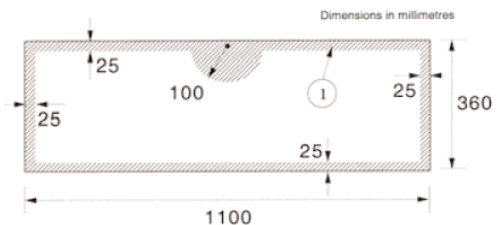

Key:

1 - excluded area

Figure 20 — Area to be excluded from the particle count determination and largest particle measurement

The particle count shall be made in the region of coarsest fracture (the aim being to obtain the minimum value). The particle count shall be made by placing a mask of (50 ± 1) mm x (50 ± 1) mm on the test piece (see Annex C). The number of crack-free particles within the mask shall be counted. A particle is 'crack-free' if it does not contain any cracks which run from one edge to another (see Figure 21).

The examination shall be completed within 5 minutes of fracturing the glass.



Figure 21 — Examples of crack-free particles and the assessment regarding the number

In the particle count, all particles wholly contained within the area of the mask shall be counted as one particle each and all the particles which are partially within the mask shall be counted as 1/2 particle each (see Annex B).

11.5 Minimum values from the particle count

In order to classify a glass as a thermally toughened soda lime silicate safety glass, the particle count of each test specimen shall not be less than the values given in Table 9.

Table 9 — Minimum particle count values

Glass type	Nominal thickness, d, mm	Minimum particle count number
Patterned	3	30
	4 to 19	40
Float and Sheet	3 to 12	40
	15 to 25	30

11.6 Selection of the longest particle

The longest particle shall be chosen from the body of the test specimen. It shall not be in the excluded area (see 11.4).

11.7 Maximum length of longest particle

In order to classify the glass as thermally toughened soda lime silicate safety glass, the length of the longest particle shall not exceed 100mm.

12 Marking

According to EN 12150-1 the thermally toughened soda lime silicate safety glass shall be marked as follows:

- Manufacturer's name or trade mark
- Number of the standard, i.e. EN 12150

To comply with UK building regulations covering accidental human impact the installed thermally toughened soda lime silicate safety glass must be indelibly marked and the marking must be visible after installation. The marking shall consist of the following:

- Manufacturer's name or trade mark
- Number of the standard, i.e. EN 12150

Classification in accordance with EN 12600, i.e. 1(C) as a minimum.

The full performance classification, i.e. 1(C) _

will be required when the glass is protecting a difference in drop.

NOTE: The _ is dependent on glass type, thickness etc.

Annex A Tolerances and distortions specific to thermally toughened soda lime silicate safety glass produced by the vertical tong hung process

A.1 Distortion

Figure A.1 — Representation of local distortion

A.1.1 Edge deformation produced by the vertical process (see 5.2.4)

The tongs used to suspend the glass during toughening result in surface depressions, known as tong marks (see Figure A.2). The centers of the tong marks are situated up to a maximum of 20 mm in from the edge. A deformation of the edge less than 2 mm can be produced in the region of the tong mark and there may also be an area of optical distortion. These deformations are included in the tolerances in Table 2.

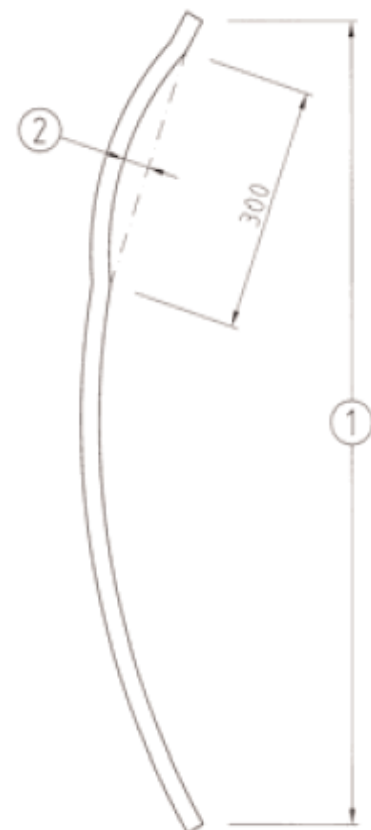

Key:

- 1 - B, or H, the side on which the tong marks occur
- 2 - local distortion

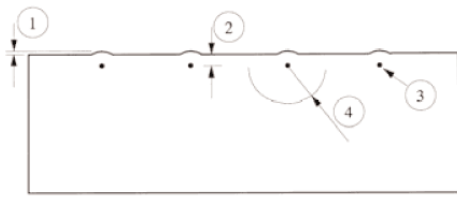

Key:

- 1 - deformation
- 2 - up to 20 mm
- 3 - tong mark
- 4 - 100 mm radius maximum area of optical distortion

Figure A.2 — Tong mark deformation

A.1.2 Measurement of local distortion (for vertical toughened glass only) (see 5.3.5)

Local distortion can occur over relatively short distances on the edge of the vertical toughened glass that contains the tong marks (see Figure A.3).

Local distortion shall be measured over a limited length of 300 mm by using a straight ruler parallel to the edge of the glass at a distance of 25 mm from the edge of the glass (see Figure A.3). Local distortion is expressed as millimetres/ 300 mm length.

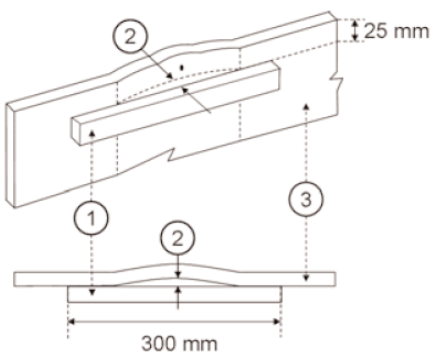

Key:

- 1 - straight edge
- 2 - local distortion
- 3 - thermally toughened glass

Figure A.3 — Measurement of local distortion

A.1.3 Limitation on overall bow and local distortion for vertical toughened glass (see 5.3.7)

The maximum allowable values for the overall bow, when measured according to 5.3.2 and the local distortion, when measured according to A.2 are given in Table A.1. The values only apply to thermally toughened soda lime silicate safety glass without holes and/or notches and/or cut-outs.

Glass type	Maximum value for distortion	
	Overall bow mm/m	Local distortion mm/ 300mm
All (a)	5,0	1,0

(a) For enamelled glass that is not covered over the whole surface the manufacturer should be consulted.

Table A.1 — Maximum values of overall bow and local distortion for vertical toughened glass

A.2 Optical distortion

A.2.1 Thermally toughened soda lime silicate safety glass produced by vertical toughening (see 8.2.2)

The distortion is generally of a random nature. However, the tong marks can produce additional optical distortion, which is generally in an area of radius 100 mm centered on the tong mark (see Figure A.2)

Annex B Alternative method of measuring roller wave

B.1 Apparatus

This is a 350 mm long aluminium channel with a centrally mounted deflection gauge/dial gauge (Figure B.1).

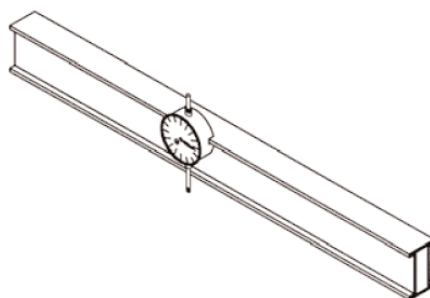

Figure B.1 — Roller wave measurement apparatus

B.2 Method

The apparatus is placed on the glass at right angles to the roller wave, so that it can bridge from peak to peak of the wave (Figure B.2).



Figure B.2 — Place the apparatus across the roller wave

The apparatus is then moved along its axis until the dial gauge reads the highest value (Figure B.3).

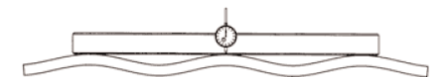

Figure B.3 — Set the zero of the gauge on a peak of the roller wave

At this point, the dial gauge is resting on a peak of the roller wave. The scale of the gauge is positioned (rotated) so that the needle points to 0 (zero) on the scale. The apparatus is then moved again along its axis until the gauge reads the lowest value (Figure B.4). At this point, the dial gauge is resting in the lowest point of the trough. The reading is then taken, and the depth of the roller wave is the difference between the zero point and the reading.

NOTE: The dial gauge scale is usually arranged so that a positive value is obtained by raising the post. Care should be taken to not misread the depth of the roller wave.



Figure B.4 — Move the gauge to a trough

The roller wave depth is recorded to the nearest 0,05 mm. y

The above procedure can be performed several times on the same pane, giving a variety of answers, since the roller waves are unlikely to be consistent. The worst roller wave of those recorded is the value of the pane.

B.3 Limitations

The apparatus should only be used on panes with a dimension larger than 600 mm at right angles to the roller wave. There is an exclusion area, 150 mm from the edge of the pane, where the apparatus should not be used.

A true measurement of roller wave can only be obtained on an otherwise flat pane of glass. If the pane has an overall bow, this will contribute to the value measured by the roller wave and must be taken into account. This can be reduced by laying the pane of glass flat on a table, which will reduce the overall bow in the pane due to the self weight of the pane, particularly with larger panes.

B.4 Alternative use of apparatus

If the dial gauge is mounted on the end of the aluminium channel rather than at the centre then it may be used for the measurement of edge lift.

Lay the test sample over the end of a table with the edge lift overhanging the edge of the support by between 50 mm and 100 mm so that the edge lift is as shown in Figure 5. Move the apparatus towards the edge of the sample. Measure the maximum deflection of the gauge from when sitting on a peak to touching the edge of the sample.

Annex C Example of particle count

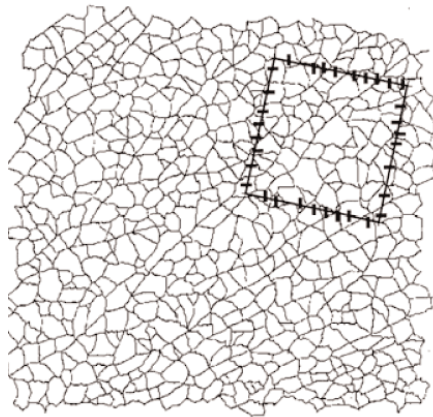

Key:

Number of perimeter particles = $32/2 = 16$

Figure C.2 — Mark and count the perimeter fragments particles as 1/2 particle each

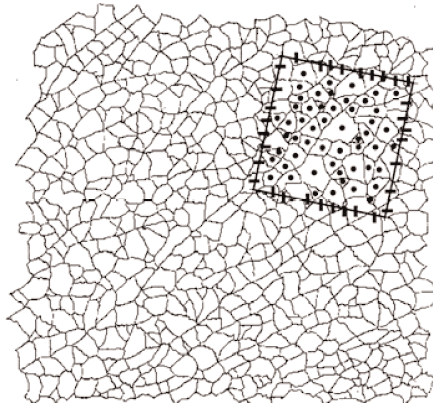

Key:

Number of central particles = 53

Total number of particles = $16 + 53 = 69$

Figure C.3 — Mark and count the central particles and add these to the perimeter count to obtain the particle count for the specimen



specimen and draw round the template.

Bibliography

BS EN 572-1: *Glass in building - Basic soda lime silicate glass products - Part 1: Definitions and general physical and mechanical properties*

BS EN 572-2: *Glass in building - Basic soda lime silicate glass products- Part 2: Float glass*

BS EN 572-4: 2005 *Glass in building - Basic soda lime silicate glass products - Part 4: Drawn sheet glass*

BS EN 572-5: *Glass in building - Basic soda lime silicate glass products - Part 5: Patterned glass*

BS EN 572-8: *Glass in building .- Basic soda lime silicate glass products - Part 8: Supplied and final cut sizes*

BS EN 572-9: *Glass in building. Basic soda lime silicate glass products- Part 9: Evaluation of conformity/Product standard*

BS EN 1096-1: *Glass in buildin - Coated glass- Part 1: Definitions and classification*

BS EN 1288-3: *Glass in building - Determination of the bending strength of glass - Part 3: Test with specimen supported at two points (four point bending)*

BS EN 12150-1: *Glass in building – Thermally toughened soda lime silicate safety glass – Part 1: Definition and description*

BS EN 12150-2: *Glass in building – Thermally toughened soda lime silicate safety glass – Part 2: Evaluation of conformity/Product standard*

BS EN 12600: *Glass in building - Pendulum test - Impact test method and classification for flat glass*

BS 6262-4: 2005 *Glazing for buildings – Part 4: Code of practice for safety related to human impact*

BS 6262-6: *Glazing for buildings – Part 6: Code of practice for special applications*

BS 8000-7: *Workmanship on building sites — Part 7: Code of practice for glazing*